

# Service Letter

## SL-MD10-003-R01

Revision 1 supersedes Initial Issue

### 1 Technical Details

#### 1.A Affected

Type: JS-MD Single

Model: JS-MD 3

up to and including S/N 3.MD109

#### 1.B Subject

Use of the JS3 Parking Brake

#### 1.C Reason

The JS-MD 3 wheel brake system is fitted with a park brake pin. Application instructions have not been defined in the Flight or Maintenance manuals.

It has been established that the frequent usage of the parking brake leads to necessary increased serviceability checks of the brake system. To avoid increased maintenance intervals and checks, this SL is published.

#### 1.D Information

*Operators are strongly recommended avoiding the use of the park brake pin until RSB SB-MD10-006 has been performed.*

#### 1.E Reference

None

#### 1.F Appendix I – Technical Information

Appendix I provides information on the park brake pin.

The parking brake is activated by a free-swivelling pin (Figure 1, Item 6) connected to the wheel brake lever (Figure 1, Item 2), which can be engaged in a recess when the brake lever is applied hard and the pilot directs the pin to the recess.

The parking brake pin is automatically disengaged by a spring when the wheel brake lever is applied sufficiently.

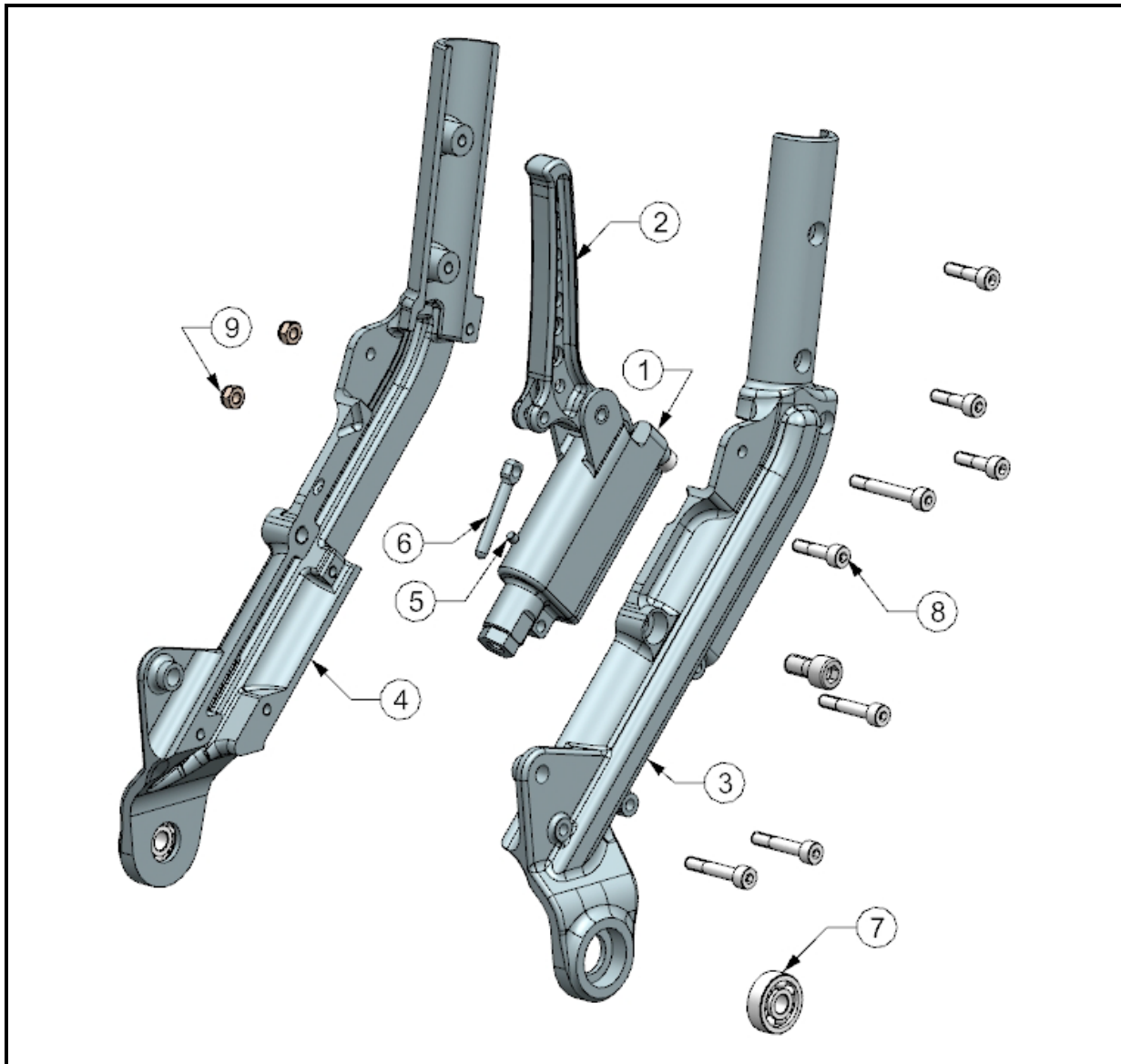

NO	DESCRIPTION	NO	DESCRIPTION
1	Brake master cylinder	6	Park brake pin
2	Brake lever	7	Bearing
3	Stick left shell	8	Cap screw
4	Stick right shell	9	Nyloc nut
5	Brake fluid magnet		

Figure 1: Stick with wheel brake system



Figure 2: Parking brake pin on the wheel brake lever